

CURVILINE



About Rollon



Development of global business

- 1975** Parent company, Rollon S.r.l., founded in Italy
- 1991** Founding of Rollon GmbH in Germany
- 1995** Expansion of headquarters to new 4,000 m² factory
Assembly starts in Germany
Quality management certified to ISO 9001
- 1998** Rollon B.V. in the Netherlands and Rollon Corporation in the USA are founded
Expansion of German branch to new 1,000 m² plant
- 1999** Founding of Rollon S.A.R.L. in France
Environmental management certified to ISO 14001
- 2000** Rollon s.r.o. founded in Czech Republic
- 2001** Expansion of headquarters to new 12,000 m² manufacturing plant
- 2007** Restructuring of the GmbH and alignment of production in Germany to customer-specific adaptations
Takeover of the assets of a manufacturer of linear rail systems
- 2008** Expansion of sales network in Eastern Europe and Asia

Continual expansion and optimization of the portfolio

Founded in 1975, Rollon manufactured high-precision linear roller bearings for the machine tool industry. Soon Rollon started manufacturing linear bearings based on the roller-cage. In 1979, Compact Rail self-aligning linear bearings joined Telescopic Rail industrial drawer slides and Easy Rail linear bearings. These products became the strong foundation on which the company is built today. Continuous optimisation of these core products remains one of the most important jobs at Rollon.

The patented Compact Rail linear bearing, which uses different proprietary rail profiles and high-precision, radial ball bearing sliders, enables compensation of height and angle mounting defects in applications and is only one example for the continuing innovative development of the existing product program.

In the same manner, we continually introduce innovative new product families emphasizing our continuing product development and optimization. These include:

- 1994 Light Rail - full and partial extensions in lightweight design
- 1996 Uniline - belt driven linear actuators
- 2001 Ecoline - aluminum economical linear system
- 2002 X-Rail - inexpensive formed steel linear bearings
- 2004 Curviline - curvilinear rails and the monorail profile rail guide
- 2007 Monorail miniature sizes

Each expansion of the product range is built on the experience of today's total of nine product families and is based on market demands. Linear technology for any application from Rollon, the total supplier.

Content

1 Product explanation	
Curvilinear rails for constant and variable radii	4
2 Technical data	
Performance characteristics and notes	6
Load capacities	7
3 Product dimensions	
Constant / variable radii rails	8
Sliders, Mounted system rails / sliders	9
4 Technical instructions	
Corrosion protection, Lubrication, Setting the preload	10

Ordering key

Ordering key with explanations

Portfolio

Product explanation

Curviline are curvilinear rails for constant and variable radii



Fig. 1

Curviline is the name of the curvilinear rail product family. They are used for all non-linear special movements. Rails with constant or variable radii may be specified according to customer requirements, resulting in a highly flexible, economical solution. Curviline is available in two rail widths. The use of standard radii is recommended. All non-standard rail layouts and radii are possible as custom products, however extra lead time may result.

Preferred areas of application of the Curviline product family:

- Packaging machines
- Railway car interior doors
- Special extensions
- Shipbuilding (interior doors)
- Food industry

The most important characteristics:

- Straight and curved partial pieces in one rail are possible
- Sliders with four rollers arranged in pairs maintain the preload over the entire rail length
- Custom production according to customer requirements

Constant radii

The layout of CKR guide rails corresponds to a partial section of a complete circle.



Fig. 2

Variable radii

CVR curvilinear rail is a variable combination of various radii and straight partial pieces.



Fig. 3

Slider

The carriage maintains the desired preload over the entire rail layout. Moving roller mountings and the paired application of concentric and eccentric roller pins ensures uniform running even with a complex rail layout.



Fig. 4

Technical data

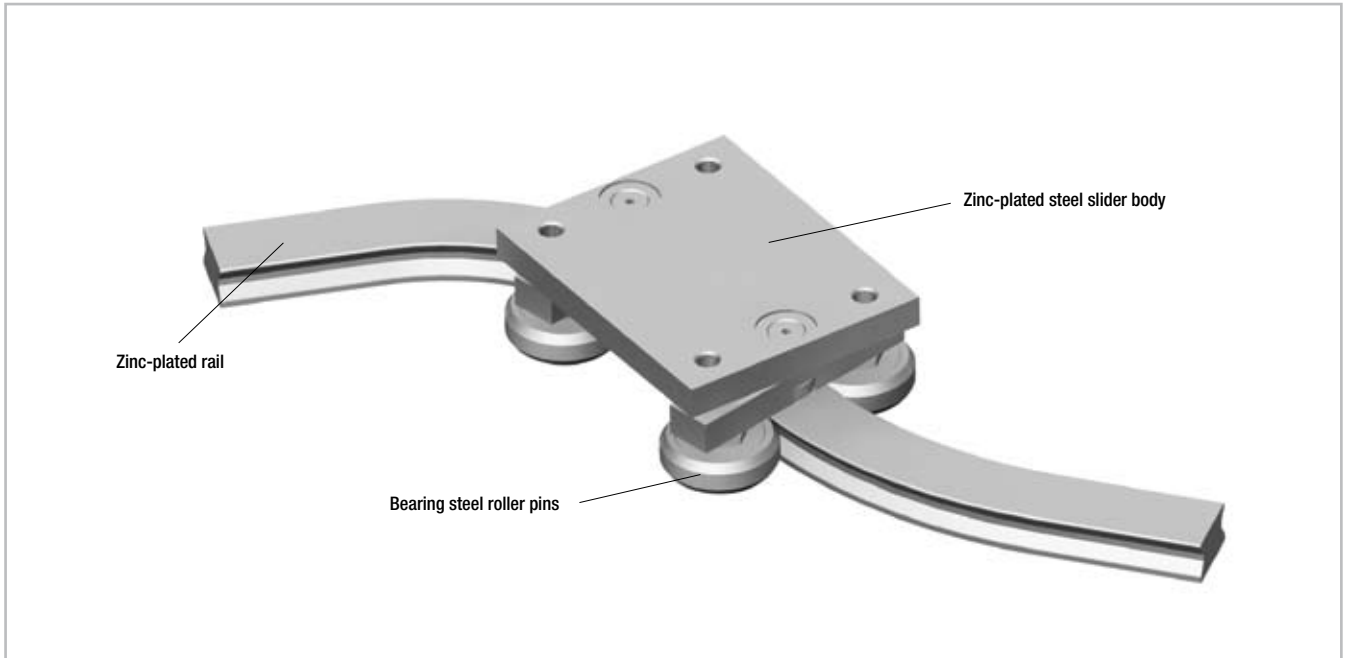

Fig. 5

Performance characteristics:

- Available rail widths: CKR01/CVR01: 16.5 mm (0.65 in) and CKR05/CVR05: 23 mm (0.91 in)
- Max. slider operating speed on the rail: 1.5 m/s (59 in/s) (depending on application)
- Max. acceleration: 2 m/s² (78 in/s²) (depending on application)
- Max. effective length of the rail: 3,240 mm (127.56 in)
- Max. traverse: CCT08: 3,170 mm (124.8 in) and CCT11: 3,140 mm (123.62 in)
- Minimum radius for both sizes: 120 mm (4.72 in).
For non-standard radii, please contact Application Technology
- Radius tolerance +/- 0.5 mm (0.02 in), angle tolerance +/- 1°
- Temperature range: -30 °C to +80 °C (-22 °F to +176 °F)
- Rails and sliders electrolytic zinc-plated as per ISO 2081; increased anticorrosive protection on request (see pg. 10 Anticorrosive protection)
- Rail material: C43
- Slider body material: Fe360
- Roller material: 100Cr6
- Roller pins lubricated for life

Remarks:

- By a simple adjustment of the eccentric roller pins (markings on bottom of roller), the slider has no clearance or is set with preload on the rails
- The recommended hole pitch is 80 mm (3.15 in) on the extended length
- Please indicate the precise rail shape and the desired hole pattern in a drawing
- Indicate if the design is a right or left version when ordering
- Composite rails are not recommended. For more information please contact Application Technology
- Resulting moment loads must be absorbed through the use of two sliders. For more information please contact Application Technology

Load capacities

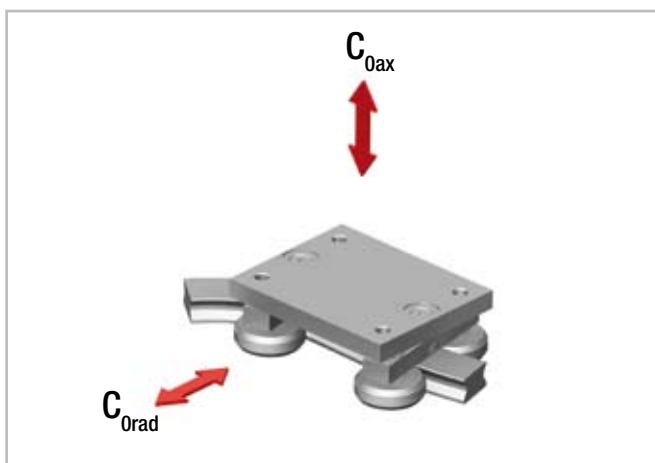

Fig. 6

Slider type	C_{0ax} [N]	C_{0rad} [N]
CCT08	400	570
CCT11	1130	1615

Resulting moment loads must be absorbed through the use of two sliders

Tab. 1

Product dimensions

Constant / variable radii rails

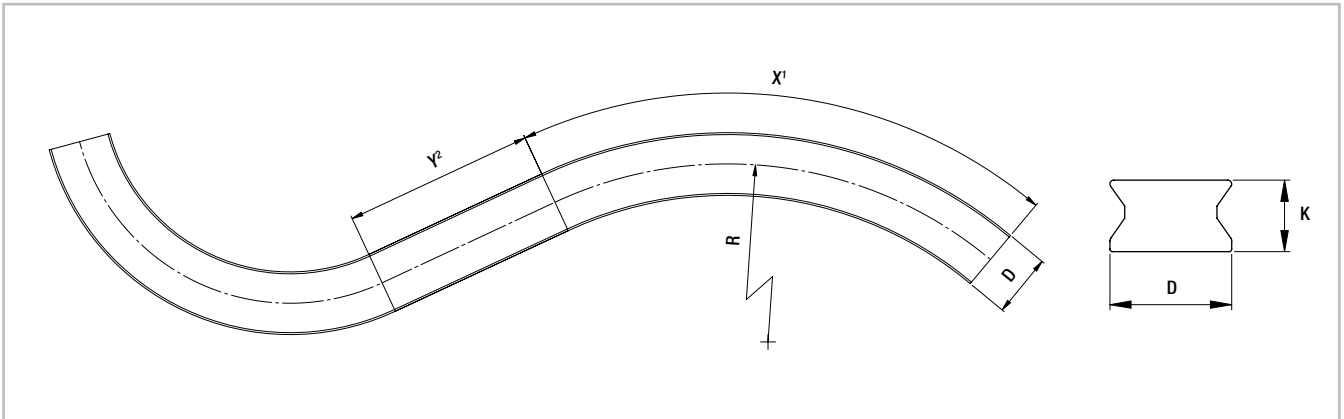

¹ The max. angle (X) is dependent on the radius
² For curvilinear rails with variable radii, Y must be at least 70 mm

Fig. 7

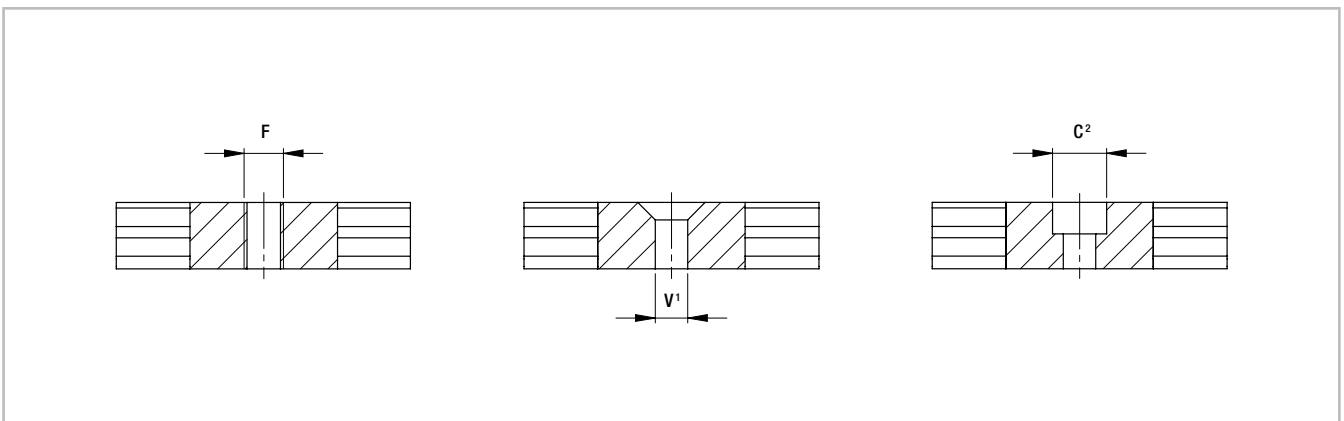

¹ Fixing holes (V) for countersunk head screws according to DIN 7991
² Fixing holes (C) for socket cap screws according to DIN 912

Fig. 8

Type	D [mm]	K [mm]	F	C	V	X	Standard radii [mm]	Y [mm]	Weight [kg/m]
CKR01 CVR01	16.5	10	up to M6	up to M5	up to M5	dependent on radius	150 - 200 - 250 - 300 - 400 - 500 - 600 - 700 - 800 - 900 - 1000	min. 70	1.2
CKR05 CVR05	23	13.5	up to M8	up to M6	up to M6				2.2

Tab. 2

Please indicate the precise rail layout and the desired hole pattern in a drawing. We recommend 80 mm (3.15 in) on the extended length as a gage for the hole pattern.

Non-standard radii are possible as special products. For more information on rail layouts, radii and hole patterns, please contact Application Technology.

Slider

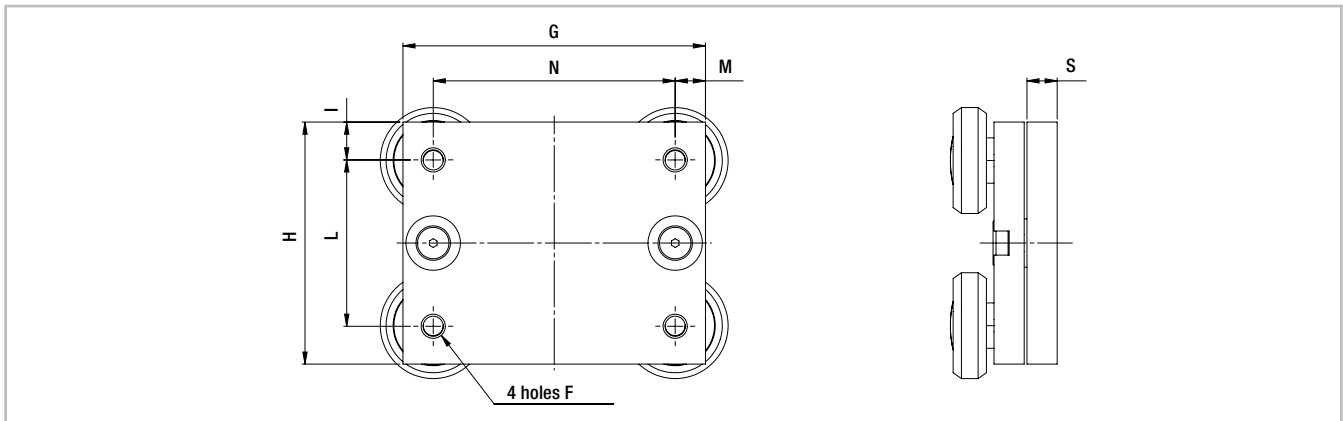

Fig. 9

Type	G [mm]	H [mm]	I [mm]	L [mm]	M [mm]	N [mm]	S [mm]	F	Weight [kg]
CCT08	70	50	10	30	10	50	10	M5	0.45
CCT11	100	80	12.5	55	10	80	10	M8	1.1

Tab. 3

Mounted sliders and rails

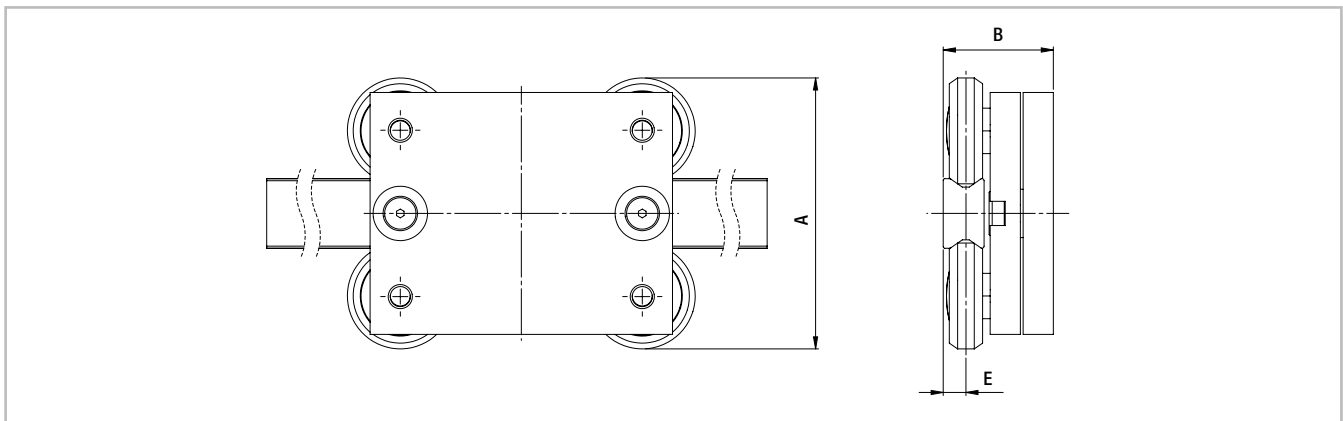

Fig. 10

Configuration	A [mm]	B [mm]	E [mm]
CKR01-CCT08 CVR01-CCT08	60	32.3	5.7
CKR05-CCT11 CVR05-CCT11	89.5	36.4	7.5

Tab. 4

Technical instructions

Anticorrosive protection

The Curviline product family has a standard anticorrosive protection by electrolytic zinc-plating according to ISO 2081. If increased anticorrosive protection is required, application-specific surface treatments are available

on request, e.g. as nickel-plated design with FDA approval for use in the food industry. For more information please contact Application Technology.

Lubrication

All roller pins of the Curviline product family are lubricated for life.

Setting the preload

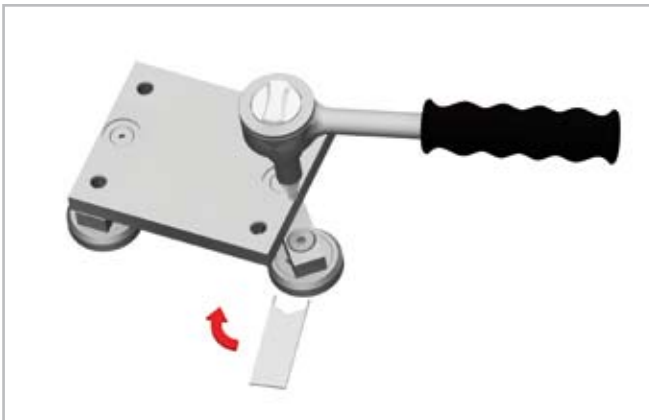

Fig. 11

If the curvilinear rails are delivered as a system, the sliders are already set with no clearance. In this case the fixing screws are secured with Loctite® at the factory.

If delivered separately, or if the sliders should be installed in another track, the eccentric roller pins must be readjusted. Important: The fixing screws must be additionally glued against loosening. The following points must also be observed:

- Wipe the raceways of any eventual dirt and debris.
- Slightly loosen the fixing screws of the roller mounting.
The eccentric roller pins are marked on the bottom.
- Position the slider(s) at the ends of the rail.
- The special flat key provided is inserted from the side onto the hexagonal of the pin to be set (see fig. 11).

Type	Tightening torque [Nm]
CCT08	7
CCT11	12

Tab. 5

- By turning the flat key clockwise the roller is pressed against the raceway and thus reduces the clearance. Observe that with increasing preload, the friction is also increased and thus the service life reduced.
- Hold the roller pin with the adjustment key in the desired position and carefully tighten the fixing screw. The exact tightening torque will be checked later.
- Move the slider on the rail and check the preload over the entire length of the rail. It should move easily and the slider should not have play at any location of the rail.
- Now tighten the fixing screws with the specified tightening torque (see tab. 5), while the flat key holds the angle adjustment of the pin. A special thread in the roller pin secures the set position.

 Notes

Ordering key

Constant radius rail / slider system

CKR01	85°	600	890	/2/	CCT08	NIC	R	
								Right or left version
								Expanded surface protection if deviation from Standard (ISO 2081) <i>see pg. 10 Anticorrosion protection</i>
						Slider type	<i>see pg. 9, tab. 3</i>	
								Number of sliders
								Rails extended length
		Radius	<i>see pg. 8, tab. 2</i>					
	Angle							
Rail type	<i>see pg. 8, tab. 2</i>							

Ordering example: CKR01-085°-0600-0890/2/CCT08-NIC-R

Note: Information for right and left side installation and for expanded surface protection is only necessary if required

Notes on ordering: Rail lengths and radii always are indicated with four digits, angles always with three digits and a zero as prefix

Exact specifications (angle, radius, hole pattern, etc.) must be represented in a drawing

Variable radius rail / slider system

CVR01	39°	200	//23°	400	297	/2/	CCT08	NIC	R
									Right or left version
									Expanded surface protection if deviation from Standard (ISO 2081) <i>see pg. 10 Anticorrosion protection</i>
							Slider type	<i>see pg. 9, tab. 3</i>	
									Number of sliders
									Rails extended length
				Radius	<i>see pg. 8, tab. 2</i>				
			Angle						
		Radius	<i>see pg. 8, tab. 2</i>						
	Angle								
Rail type	<i>see pg. 8, tab. 2</i>								

Ordering example: CVR01-039°-0200//023°-0400-0297/2/CCT08-NIC-R

Note: Data for angles and respective radii are in sequential order

Note: Information for right and left side installation and for expanded surface protection is only necessary if required

Notes on ordering: Rail lengths and radii always are indicated with four digits, angles always with three digits and a zero as prefix

Exact specifications (layout, angle, radius, hole pattern, etc.) must be represented in a drawing

Constant radius rails

CKR01	120°	600	1152	NIC	R	
						Right or left version
						Expanded surface protection if deviation from Standard (ISO 2081) <i>see pg. 10 Anticorrosion protection</i>
						Rails extended length
		Radius	<i>see pg. 8, tab. 2</i>			
	Angle					
Rail type	<i>see pg. 8, tab. 2</i>					

Ordering example: CKR01-120°-0600-1152-NIC-R

Note: Information for right and left side installation and for expanded surface protection is only necessary if required

Notes on ordering: Rail lengths and radii always are indicated with four digits, angles always with three digits and a zero as prefix

Exact specifications (angle, radius, hole pattern, etc.) must be represented in a drawing

Variable radius rails

CVR01	39°	200	//23°	400	297	NIC	R
							Right or left version
							Expanded surface protection if deviation from Standard (ISO 2081) <i>see pg. 10 Anticorrosion protection</i>
							Rails extended length
		Radius	<i>see pg. 8, tab. 2</i>				
			Winkel				
		Radius	<i>see pg. 8, tab. 2</i>				
	Angle						
Schienentyp	<i>see pg. 8, tab. 2</i>						

Ordering example: CVR01-039°-0200//023°-0400-0297-NIC-R

Note: Data for various angles and respective radii are in sequential order

Note: Information for right and left side installation and for expanded surface protection is only necessary if required

Notes on ordering: Rail lengths and radii always are indicated with four digits, angles always with three digits and a zero as prefix

Exact specifications (layout, angle, radius, hole pattern, etc.) must be represented in a drawing

Slider

CCT08	NIC	
		Expanded surface protection if deviation from Standard (ISO 2081) <i>see pg. 10 Anticorrosion protection</i>
Slider type	<i>see pg. 9, tab. 3</i>	

Ordering example: CCT08-NIC

Note: Information for expanded surface protection are only necessary when needed

Portfolio



COMPACT RAIL

Rugged roller sliders with innovative self adjustment



MINIATURE MONO RAIL

Miniature format profile guideways with unique ball design

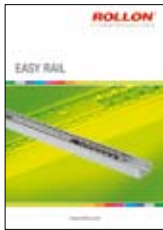

EASY RAIL

Compact, versatile linear bearings

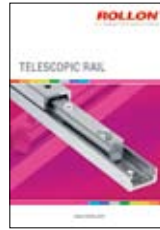

TELESCOPIC RAIL

Smooth-running telescopic linear bearing drawer slides with low deflection under heavy loads



UNILINE

Steel-reinforced, belt-driven linear actuators with hardened steel linear bearings and precision radial ball bearing rollers



X-RAIL

Roller embossed stainless steel profiles for the use in rough environments



MONO RAIL

Profile guideways for highest degrees of precision

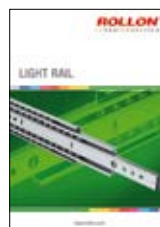

LIGHT RAIL

Full and partial extension, lightweight drawer slides

Fold out ordering key

To make this product catalog as simple as possible for you to use, we have included the following easy-to-read chart.

Your advantages:

- Description and ordering designations easy to read at one glance
- Simplified selection of the correct product
- Links to detailed descriptions in the catalog



Italy

ROLLON S.r.l.

Via Trieste 26
I-20059 Vimercate (MB)
Tel.: (+39) 039 62 59 1
Fax: (+39) 039 62 59 205
E-Mail: infocom@rollon.it
www.rollon.it

Germany

ROLLON GmbH

Voisweg 5c
D-40878 Ratingen
Tel.: (+49) 21 02 87 45 0
Fax: (+49) 21 02 87 45 10
E-Mail: info@rollon.de
www.rollon.de

France

ROLLON S.A.R.L.

Les Jardins d'Eole, 2 allée des Séquoias
F-69760 Limonest
Tel.: (+33) (0)4 74 71 93 30
Fax: (+33) (0)4 74 71 95 31
E-Mail: infocom@rollon.fr
www.rollon.fr

Netherlands

ROLLON B.V.

Edisonstraat 32b
NL-6902 PK Zevenaar
Tel.: (+31) 31 65 8 19 99
Fax: (+31) 31 63 4 12 36
E-Mail: info@rollon.nl
www.rollon.nl

USA

ROLLON Corporation

30A Wilson Drive
Sparta, NJ 07871, USA
Tel.: (+1) 973 300 5492
Fax: (+1) 973 300 9030
E-Mail: info@rolloncorp.com
www.rolloncorp.com

All addresses of our global sales partners can also be found in the internet at www.rollon.com